

AEF012



SPIRAL MIXER 12Kg

CC_003-14

Flour capacity* (Kg)-(lb)
Min 0,6 (1,32) Max 12 (26,46)
Bowl volume (l)
29
Power (kW)-(hp)
230V.1ph.50~60Hz 1 Speed 1,5 (2) 2 Speeds 1,5 (2) 230V.3ph.50~60Hz 1 Speed 0,55 (0,75) 2 Speeds 2,2 (3) 400V.3ph.50~60Hz 1 Speed 0,55 (0,75) 2 Speeds 2,2 (3)
Net weight (Kg)-(lb)
188 (414,46)
Dimensions (mm)-(in)
A 475 (18 11/16) B 740 (29 1/8) C 1082 (42 5/8) C (**) 1103 (43 7/16) D 682 (26 7/8) E 100 (3 15/16)



* Based on: 60% Dough Hydration, 12% Flour Moisture, 2°C Water

** Dimension for machine with touchscreen option

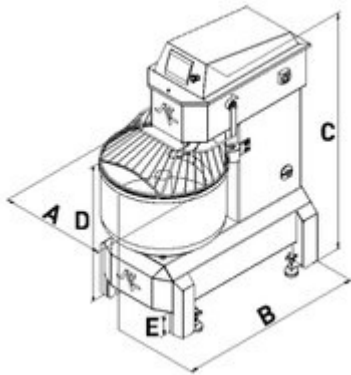
**Main features**

- 55-100% hydration: excellent oxygenation and water absorption in the dough
- 0-8 working hours
- Standard - white painted carbon steel frame
- Feet in AISI 304 stainless steel and castors
- 2 synchronized speeds (hook and bowl)
- Bowl with central poste
- Allows 5% of the total bowl capacity to be kneaded
- Drain cap
- Bowl reversal
- Digital control
- Security cover in technical polymer
- Spiral hook in AISI stainless steel
- CE

Options

- Stainless steel AISI 304 frame
- Closed security cover in AISI 304 stainless steel
- Security cover
- Paddle
- Scraper
- Analog control
- Touchscreen
- Inverter (multispeed)
- Marine-USPHS upgrade to inox models
- Marine-IPX5 upgrade to inox models
- UL-NSF

- NR12

Accessories

- Water meter (external)



Contact our team for enquiries.

Commercial: 0800 428 733 | **Domestic Products:** 0800 697 465 | **Service:** 0800 178 349

www.rewardhospitality.co.nz

